

E.1000.R.AA.C

CLIENT

REFERENCE

FIVE DOCK

ADDRESS

TOP

ECOLIFT
SYDNEY-AUSTRALIA

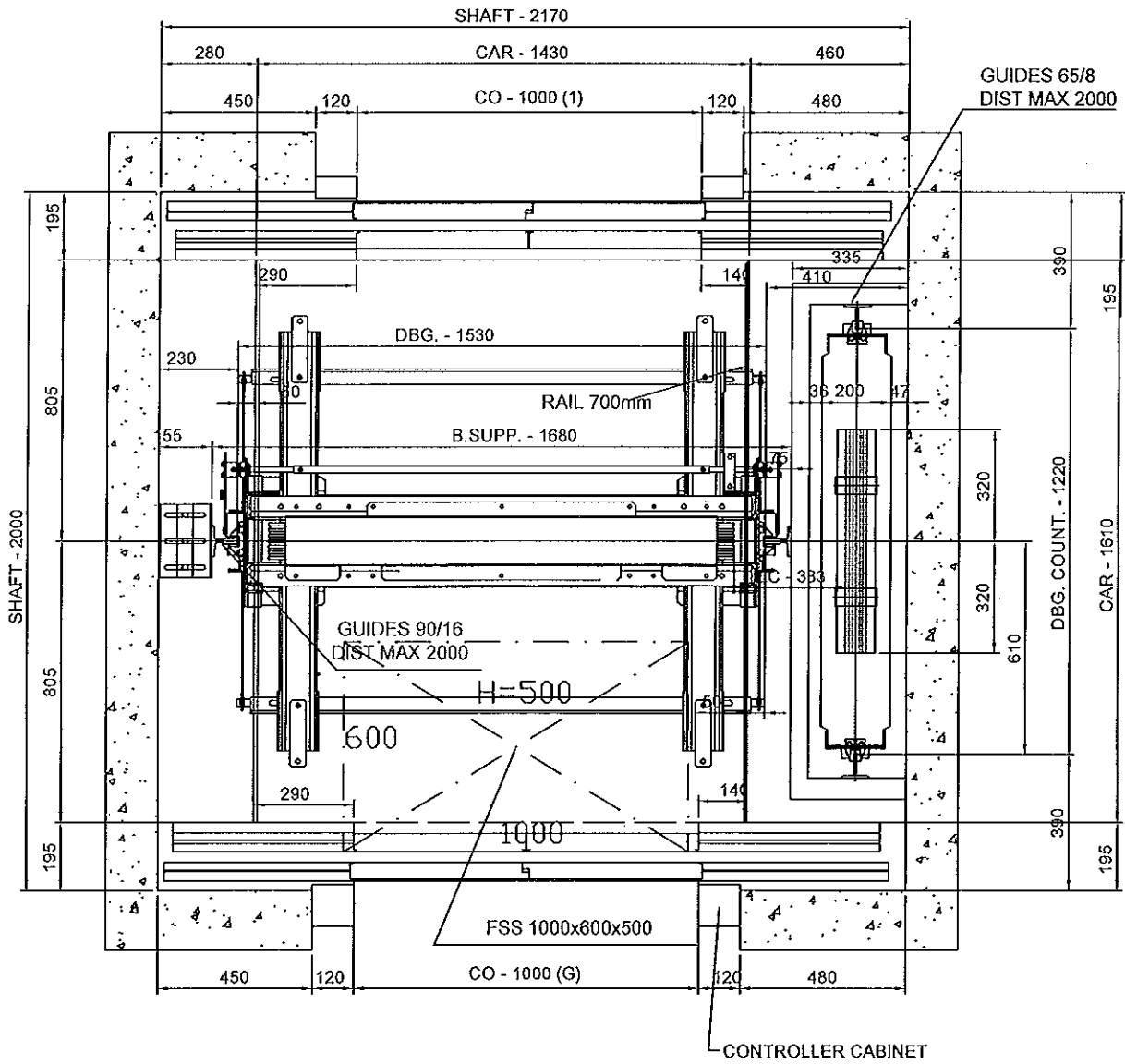

CLIENT AGREEMENT		MODIFIC.	DATE	ELEVATOR CHARACTERISTIC					
		01		TYPE	ELEC.	LOAD	1000	PEOPLE	13
		02		STOPS	3	POWER	380V	SPEED	1 m/s
		03		GUIDE CHARACTERISTIC					
DATE :		NAME	DATE	TYPE	90/16-70/9	DIST B.G.	1410-1220	DIST. MAX. SUP.	2000
SCALE	MAKE	AH	4.11.16	CABIN DOOR					
1/20	REVIEWED			TYPE	AUTO	CLEAR OPENING	1000	HAND	CENT
REMARKS				LANDING DOOR					
				TYPE	AUTO	CLEAR OPENING	1000	HAND	CENT