

E.1000.R.AA.C

ECOLIFT

SUPPLY

155328



REFERENCE

SYDNEY COUNCR

TOP

ADRESS

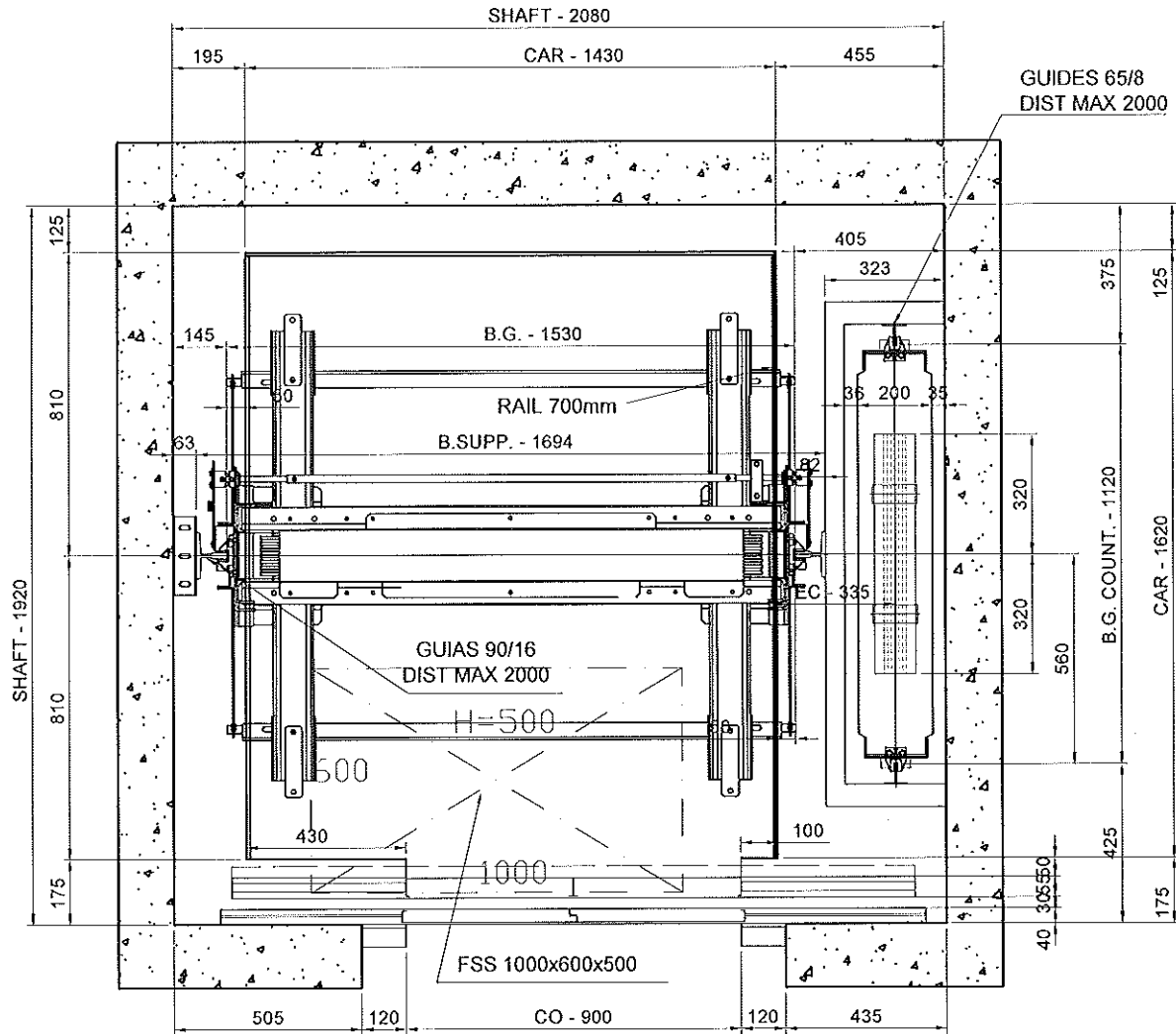

CLIENT AGREEMENT		MODIFIC.	DATE	ELEVATOR CHARACTERISTIC					
		01		TYPE	ELEC.	LOAD	1000	PEOPLE	13
		02		STOPS	2	POWER	380V	SPEED	1 m/s
		03		GUIDE CHARACTERISTIC					
DATE :		NAME	DATE	TYPE	90/16-65/8	DIST B.G.	1530-1120	DIST. MAX. SUP.	2000
SCALE	MAKE	AH	26.10.15	CABIN DOOR					
1/20	REVIEWED			TYPE	AUTO	CLEAR OPENING	900	HAND	CENT
				LANDING DOOR					
REMARKS				TYPE	AUTO	CLEAR OPENING	900	HAND	CENT